



Design	
Color/Finish	White
Display	Touch UI
Control	Electronic
Door Hinge	Sliding Hinge
Interior Lighting	LED
Total Capacity	247 liters (HK) / 246 liters (SG)
Net Weight	55 kg
Dimensions	W 540mm x H 1770mm x D 545mm
Performance	
Features	6th Sense Fresh Control Zen Inverter Technology Fast Freezing Multi Air Flow Touch User Interface Fresh Box with Humidity Control Dairy Compartment Reversible Door Temperature Alarm Total No Frost
Compressor Type	Inverter
Refrigerant	R600a
Refrigerator	
Total Volume Compartments	180 liters Glass Shelves x 4, Fresh Box with Humidity Control, Dairy Compartment, Half Balcony x 3, Full Balcony x 1, Egg Tray x 1
Freezer	
Total Volume Compartments	67 liters (HK) / 66 liters (SG) Easy Access Tray x 1, Drawer x 2, Ice Tray x 1
Consumption Rates	
Energy Consumption	168 kWh/year (HK) 273 kWh/year (SG)
Accessories	
IFU, Ice Tray, Egg tray	

Features & Benefits

	<p><6th Sense Fresh Control> It can adjust the temperature and humidity level automatically for keeping food fresh for a prolonged time.</p>
	<p><Zen Inverter Technology> Silence Control, reduce energy consumption and achieve the ideal temperature in a short time.</p>
	<p><Fresh Box with Humidity Control> The humidity regulator in Fresh Box allows consumers to store food in a flexible way. Fruit & veggies stay fresh for up to 15 days.*</p>
	<p><Easy Access Tray> Giving consumers the convenience to store handy items in the freezer.</p>
	<p><Fast Freezing> To preserve at best, this function helps to quickly cool the freezing compartment or quickly turn a large capacity of food to be frozen in the freezer.</p>
	<p><Reversible Door> The door hinge is interchangeable, providing a flexible configuration to suit any kitchen format.</p>

*Based on weight loss and visual quality, considering common fruits and vegetables. Internal test procedure.

Recommended Retail Price
TBA

Technical Specifications

Climate Class	SN - T Class
Voltage	220 - 240 vac
Length of Electrical Cord	245 cm
Packaging Dimensions	W 580mm x H 1840mm x D 608mm
Gross Weight	57 Kg
Place of Manufacture	Italy

Control Panel

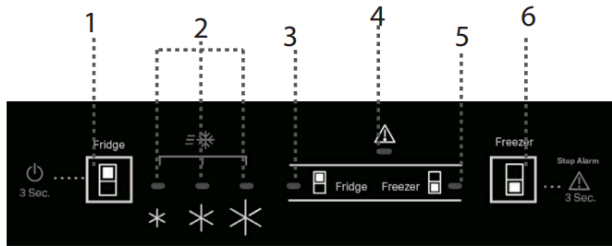

- 1. Refrigerator Temperature / Stand By
- 2. Temperature Indicator setting
- 3. Refrigerator Indicator
- 4. Alarm Indicator
- 5. Freezer Indicator
- 6. Freezer Temperature / Stop Alarm

Installation Information

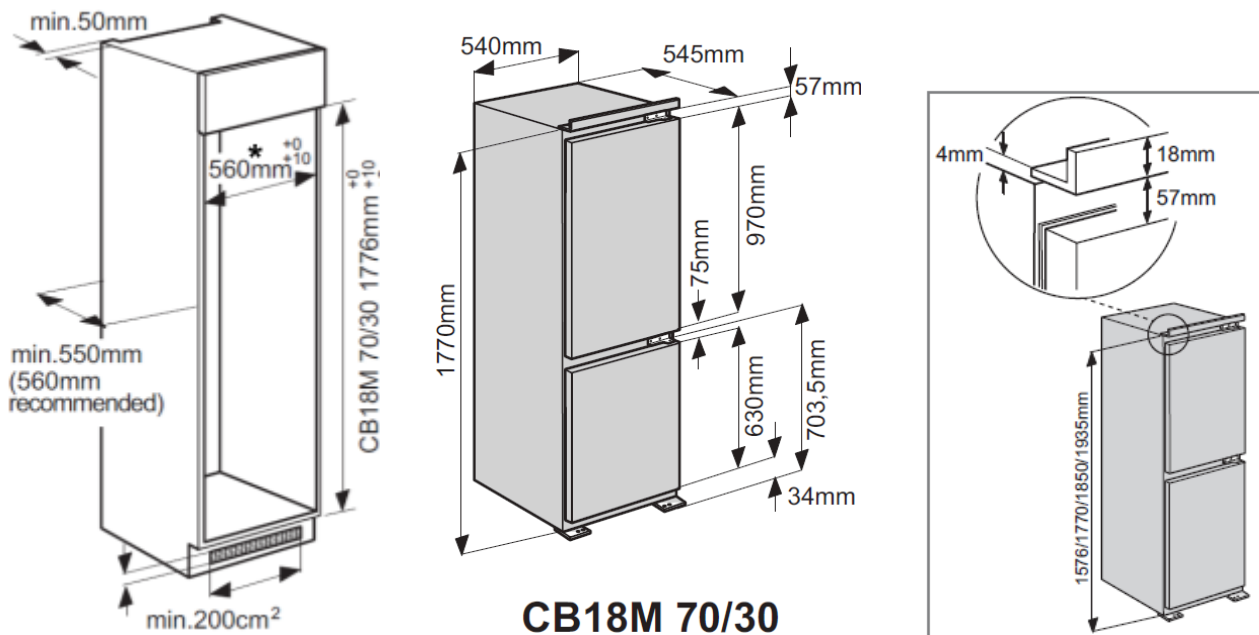

* Above cutout dimensions stated **is not included** with the dimensions of the cabinet door hinge.