

Whirlpool

Multifunction Oven

AKZ661IXS

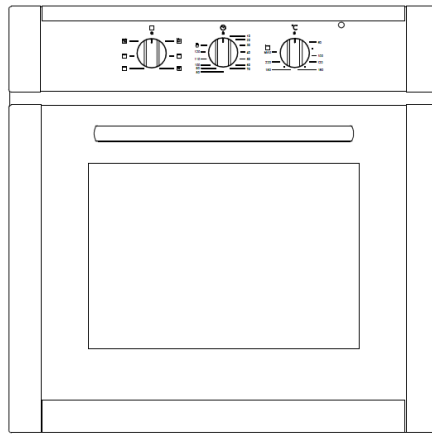

Instructions for installation and use

技术要求:

1. 材质:铜版纸;
2. 印刷字迹清晰明了;
3. 外形尺寸为A4大小。
4. 图为说明书封面, 颜色以电子为准。

| | | | | | | | | | | |
|----|-----|------------|----------|-----|------------|------------------------|----|----|-----------------------|--|
| | | | | | | 旧品号 43090374 | | | | |
| | | | | | | 名称 新加坡惠而浦 | | | 图号 | |
| | | | | | | F62TIX (AKZ661IXS) 说明书 | | | FSMS-Whirlpool-03-001 | |
| A | | | P17QK140 | 蔡丽君 | 2017.10.13 | 品号 40300200344 | | | 材料 | |
| 标记 | 处数 | 分区 | 更改文件号 | 签名 | 年月日 | | | | 铜版纸 | |
| 设计 | 蔡丽君 | 2017.10.13 | 标准化 | | | 阶段标记 | 数量 | 比例 | | |
| 校对 | | | | | | | 1 | | | |
| 审核 | | | | | | | | | 浙江安德电器有限公司 | |
| 工艺 | | | 批准 | | | 共 1 张 第 1 张 | | | | |

Whirlpool

Multifunction Oven

AKZ661IXS

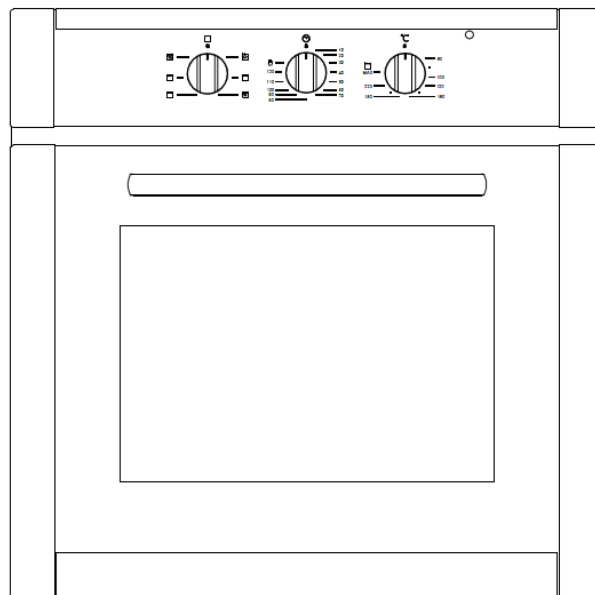

Instructions for installation and use

We recommend that you read the instructions in this owner's manual carefully before use for the best performance and to extend the life of your appliance, as it will provide you with all the instructions you require to ensure its safe installation, use and maintenance. Always keep this owner's manual close to hand since you may need to refer to it in the future. Thank you.

Close-up view

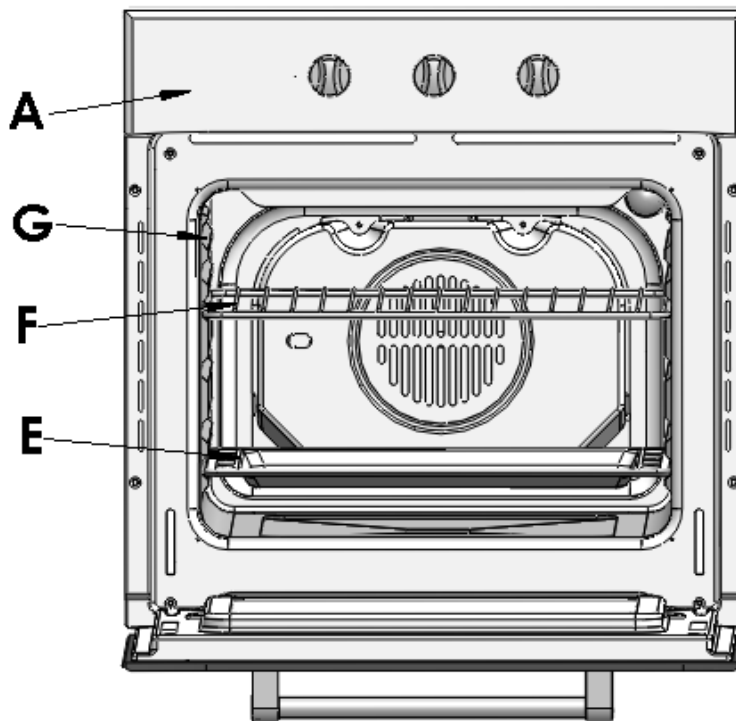

5-FUNCTION MODEL

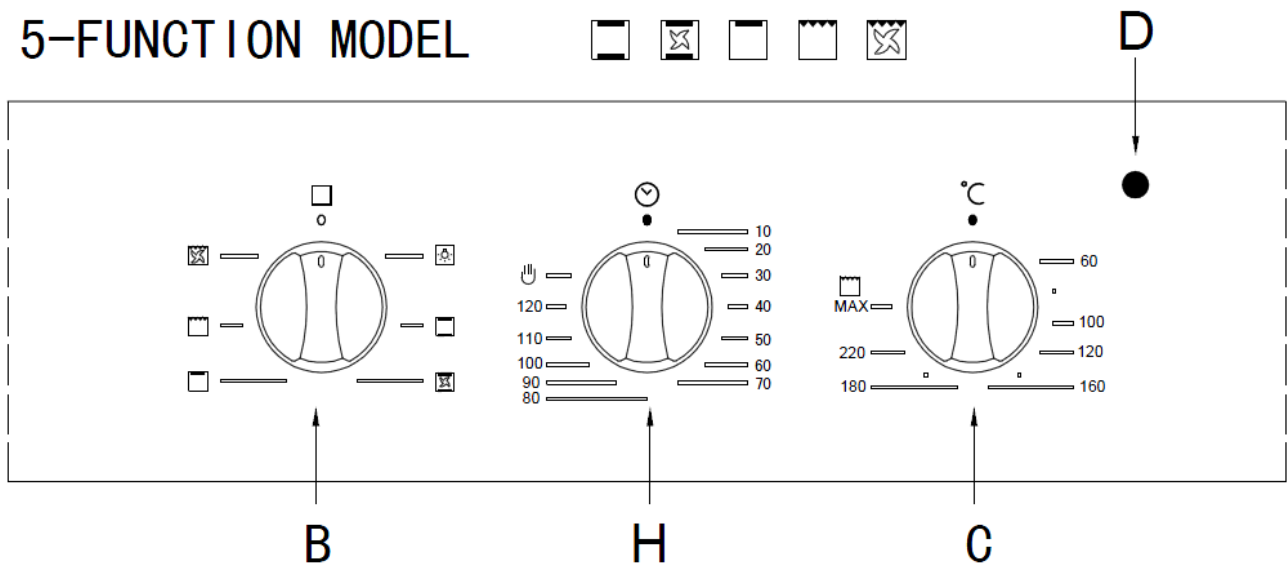

- A. Control Panel
- B. Cooking mode selection knob
- C. Cooking temperature selection knob
- D. Oven indication light (only available on certain models)
-When lit, it indicates the ovens is heating up to the temperature set
- E. Dripping Pan or Baking Sheet
- F. Oven Rack
- G. Guides for sliding the racks or dripping in and out
- H. End Cooking Time Knob

How to use your oven

This multi-function oven combines the advantages of traditional convection ovens with those of the more modern fan assisted models in a single appliance.

It is an extremely versatile appliance that allows you to choose easily and safely between different cooking modes. The various features offered by the oven are selected by means of selector knob “B” and thermostat “C” situated on the control panel.

Push-in control knob (only available on certain models)

Control knob can be pushed in, and you can push the control knob lightly to release it or lock it.

Notice: The first time you use your appliance, we recommend that set the thermostat to the highest setting and leave the oven on for about half an hour with nothing in it, with the oven door shut. Then, open the oven door and let the room air in. The odor that is often detected during this initial use is due to the evaporation of substances used to protect the oven during storage and until it is installed.

Notice: Place the dripping pan provided on the bottom shelf of the oven to prevent any sauce and/or grease from dripping onto the bottom of the oven only when grilling food or when using the rotisserie (only available on certain models). For all other types of cooking, never use the bottom shelf and never place anything on the bottom of the oven when it is in operation because this could damage the enamel. Place your cookware (dishes, aluminum foil, etc. etc.) On the grid provided with the appliance inserted especially along the oven guides.

Notice: to use the oven in manual mode (not using the end cooking time programmer); the  symbol must be aligned with the reference mark on the control panel.

Convection mode  2100-2520W

Position of thermostat knob “C”: between 60°C and Max. On this setting, the top and bottom heating elements come on. This is the classic, traditional type of oven which has been perfected, with heat distribution and reduced energy consumption. The convection oven is still unequalled when it comes to cooking dishes made up of ingredients, e.g. cabbage with ribs, Spanish style cod, Ancona style stockfish, tender veal strips with rice, etc. Excellent results are achieved when preparing veal or beef-based dishes as well (braised meats, stew, goulash, wild game, ham etc.) which need to cook slowly and basting or the addition of liquid. It remains the best system for baking cakes as well as fruit and cooking using covered casserole dishes for oven baking. When cooking in convection mode, only use one dripping pan or cooking rack at a time, otherwise the heat distribution will be uneven. Using the different rack heights available, you can balance the amount of heat between the top and the bottom of the oven. Select from among the various rack heights based on whether the dish needs more or less heat from the top.

“Fast cooking” Mode  2125-2560W

Position of thermostat knob “C”: Between 60°C and Max. The top and bottom heating elements, as well as the fan, will come on, guaranteeing constant heat distributed uniformly throughout the oven.

This mode is especially recommended for cooking pre-packed food quickly (as pre-heating is not necessary), such as for example: frozen or pre-cooked food) as well as for a few “home-made” dishes.

The best results when cooking using the “Fast cooking” mode are obtained if you use one cooking only (the second from the bottom), please see the table entitled “Practical Cooking Advice”.

“Top” oven  940-1110W

Position of thermostat knob “C”: Between 60°C and Max. The top heating element comes on. This mode can be used to brown food at the end of cooking.

Grill  2090-2520W

Position of thermostat knob “C”: Max. The top central heating elements come on. The extremely high and direct temperature of the grill makes it possible to brown the surface of meats and roasts while locking the juices in to keep them tender. The grill is also highly recommended for dishes that require a high temperature on the surface: beef steaks, veal, rib steak, filets, hamburgers etc. ...

Cook food with the oven door ajar.

Some grilling examples are included in the “Practical Cooking Advice” paragraph.

Fan Assisted Grill  2100-2550W

Position of thermostat knob “C”: Between 60°C and 200°C. The top central heating elements and the fan come on. This combination of features increases the effectiveness of the unidirectional thermal radiation of the heating

elements through forced circulation of the air throughout the oven. This helps prevent food from burning on the surface, allowing the heat to penetrate right into the food. Excellent results are achieved with kebabs made with meats and vegetables, sausages, ribs lamb chops, chicken in a spicy sauce, quail, pork chops, etc.

Cook food in “fan assisted grill mode ” with the oven door shut .

This mode is also ideal for cooking fish steaks, like swordfish, stuffed cuttlefish etc.

End Cooking Time Knob (H) (only available on certain models)

This model is equipped with a timer to control when the oven shuts off during cooking. Position of timer knob “H” :Between **10minutes** and **120 minutes**.

At the end of the programmed length of time, the timer will sound and automatically turn off the oven.

The oven light

Set knob “B” to the  symbol to turn it on .It lights the oven and stays on when any of the electrical heating elements in the oven come on.

Cooling ventilation

In order to cool down the exterior of the appliance, this model is equipped with a cooling fan, which comes on automatically when the oven is hot.

When the fan is on, a normal flow of air can be heard exiting between the oven door and the control panel.

Note: When cooking is done, the fan stays on until the oven cools down sufficiently.

How to Keep Your Oven in Shape

Before cleaning your oven, or performing maintenance, disconnect it from the power supply.

To extend the life of your oven, it must be cleaned frequently, keeping in mind that:

- the enameled or stainless steel parts should be washed with lukewarm water without using any abrasive powders or corrosive substances which could ruin them ;Stainless steel could get stained .If these stains are difficult to remove, use special products available on the market. After cleaning, it is advisable to rinse thoroughly and dry.
- the inside of the oven should preferably be cleaned immediately after use ,when it is still warm ,with hot water and soap ;The soap should be rinsed away and the interior dried thoroughly. Avoid using abrasive detergents (for example cleaning powders, etc) and abrasive sponges for dishes or acids (such as lime scale –remover, etc…) as these could damage the enamel .If the grease spots and dirt are particularly tough to remove, use a special product for oven cleaning, following the instructions provided on the packet. Never use a steam cleaner for cleaning inside of oven.
- if you use your oven for an extended period of time ,condensation may form .Dry it using a soft cloth.
- there is a rubber seal surrounding the oven opening which guarantees its perfect functioning .Check the condition of this seal on a regular basis .If necessary, clean it and avoid using abrasive products or objects to do so. Should it become damaged, please contacts you're nearest After-sales Service Center .We recommend you avoid using the oven until it has been repaired.
- never line the oven bottom with aluminum foil ,as the consequent accumulation of heat could compromise the cooking and even damage the enamel .
- clean the glass door using non-abrasive products or sponges and dry it with a soft cloth .

How to Remove the Oven door

For a more thorough clean, you can remove the oven door. Choose the remove and assemble method

According to different structure of oven door purchased. Proceed as follows:

Oven door structure **1** remove and assemble procedure:

- Open the door fully ;
- Lift up and turn the small levers situated on the two hinges ;
- Grip the door on the two external sides ,shut it slowly but not Completely;
- Pull the door towards you ,pulling it out of its seat ;

Reassemble the door by following the above procedures backwards.

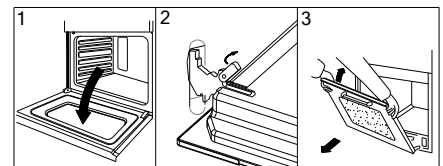

Replacing the Oven Lamp

- Disconnect the oven from the power supply by means of the omni polar switch used to connect the appliance to the electrical mains ;or unplug the appliance if the plug is accessible ;
- Remove the glass cover of the lamp-holder ;
- Remove the lamp and replace with a lamp resistant to high temperatures (300 °C)with the following

characteristics:

- Voltage: 220-240V
- Wattage: 25W
- Type: E 14

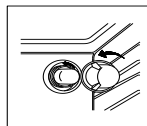

- Replace the glass cover and reconnect the oven to the mains power supply .

Practical Cooking Advice

The oven offers a wide range of alternatives which allow you to cook any type of food in the best possible way. With time you will learn to make the best use of this versatile cooking appliance and the following directions are only a guideline which may be varied according to your own personal experience.

Preheating

If the oven must be preheated (this is generally the case when cooking leavened foods),the “**Multi-Cooking**” mode and the “**Fast cooking**” mode can be used to reach the desired temperature as quickly as possible in order to save on energy .

Once the food has been placed in the oven, the most appropriate cooking mode can then be selected.

Using the “Fast Cooking” Mode

Functional,fast and practical for those of you who use pre-packed products (such as for example:frozen or pre-cooked food) along with other food items.You will find useful suggestions in the “Practical Cooking Advice” table.

Using the Grill

This multi-function oven offers you **2 different grilling modes.**

Use the “**grill**” mode  , placing the food under the center of the grill (situated on the 3rd or 4th rack from the bottom)because only the central part of the top heating element is turned on .

Use the bottom rack (1st from the bottom), placing the dripping pan provided to collect any sauce and /or grease and prevent the same from dripping onto the oven bottom. When using this mode, we recommend you set the thermostat to the highest setting. However, this does not mean you cannot use lower temperatures, simply by adjusting the thermostat knob to the desired temperature.

Setting  “**fan assisted grill**” , is extremely useful for grilling foods rapidly ,as the distribution of heat makes it possible not only to brown the surface ,but also to cook the bottom part .

Moreover, it can also be used for browning foods at the end of the cooking process, such as adding that gratin finish to pasta bakes, for example.

When using this mode, place the grid on the 2nd or 3rd oven rack from the bottom (see cooking table) then ,to prevent fat and grease from dripping onto the bottom of the oven and thus smoke from forming ,place a dripping-pan on the 1st rack from the bottom.

When using this mode ,we advise you to set the thermostat to 200°C,as it is the most efficient way to use the grill ,which is based on the use of infrared rays .However, this does not mean you cannot use lower temperatures, simply by adjusting the thermostat knob to the desired temperature.

Therefore the best results when using the grill modes are obtained by placing the grid on the lower racks (see cooking table) then, to prevent fat and grease from dripping onto the bottom of the oven and smoke from forming, place a dripping-pan on the 1st oven rack from the bottom.

Baking Cakes

When baking cakes ,always place them in a preheated oven .Make sure you wait until the oven has been preheated thoroughly (the end light “**D**” will turn off).Do not open the oven door during baking to prevent the cake from dropping .In general:

Pastry is too dry

Increase the temperature by 10°C and reduce the cooking time .

Pastry dropped

Use less liquid or lower the temperature by 10°C .

Pastry is too dark on top

Place it on a lower rack, lower the temperature, and increase the cooking time.

Cooked well on the inside but sticky on the outside

Use less liquid, lower the temperature, and increase the cooking time.

The Pastry sticks to the pan

Grease the pan well and sprinkle it with a dusting of flour or use greaseproof paper.

I used more than one level (in the function “ventilated oven ”) and they are not all at the same cooking point

Use a lower temperature setting .It is not necessary to remove the food from all the racks at the same time.





Cooking Fish and Meat

When cooking white meat ,fowl and fish ,use temperature setting from 180°C to 200°C.

For red meat that should be well done on the outside while tender and juicy in the inside ,it is a good idea to start with a high temperature setting (200°C-220°C) for a short time ,then turn the oven down afterwards.

In general, the larger the roast, the lower the temperature setting. Place the meat on the center of the grid and place the dripping pan beneath it to catch the fat.

Make sure that the grid is inserted so that it is in the center of the oven .If you would like to increase the amount of heat from below, use the low rack heights .For savory roasts (especially duck and wild game), dress the meat with lard or bacon on the top.

| Selector knob setting | Food to be cooked | Weight (in kg) | Cooking rack position from bottom | Preheating time (Minutes) | Thermostat knob setting | Cooking time (Minutes) | |
|--|--|--|-----------------------------------|---------------------------|-------------------------|-------------------------|-------|
| 1 Convection  | Duck | 1 | 3 | 15 | 200 | 65-75 | |
| | Roast veal or beef | 1 | 3 | 15 | 200 | 70-75 | |
| | Pork roast | 1 | 3 | 15 | 200 | 70-80 | |
| | Biscuits (short pastry) | - | 3 | 15 | 180 | 15-20 | |
| | Tarts | 1 | 3 | 15 | 180 | 30-35 | |
| 2 Top Oven  | Browning food to perfect Cooking | - | 3/4 | 15 | 220 | - | |
| 3 Grill  | Soles and cuttlefish | 1 | 4 | 5 | Max | 8-10 | |
| | Squid and prawn kebabs | 1 | 4 | 5 | Max | 6-8 | |
| | Cod filet | 1 | 4 | 5 | Max | 10 | |
| | Grilled vegetables | 1 | 3/4 | 5 | Max | 10-15 | |
| | Veal steak | 1 | 4 | 5 | Max | 15-20 | |
| | Cutlets | 1 | 4 | 5 | Max | 15-20 | |
| | Hamburgers | 1 | 4 | 5 | Max | 7-10 | |
| | Mackerels | 1 | 4 | 5 | Max | 15-20 | |
| | Toasted sandwiches | - | 4 | 5 | Max | 2-3 | |
| | With rotisserie (where prevent) | | | | | | |
| | | Veal on the spit | 1.0 | - | 5 | Max | 80-90 |
| | | Chicken on the spit | 1.5 | - | 5 | Max | 70-80 |
| | | Lamb on the spit | 1.0 | - | 5 | Max | 70-80 |
| | 4 Fan Assisted Grill  | Grilled chicken | 1.5 | 3 | 5 | 200 | 55-60 |
| Cuttlefish | | 1.5 | 3 | 5 | 200 | 30-35 | |
| With rotisserie (where prevent) | | | | | | | |
| | | Veal on the spit | 1.5 | - | 5 | 200 | 70-80 |
| | | Chicken on the spit | 2.0 | - | 5 | 200 | 70-80 |
| | | Chicken (on the spit)+potatoes (roasted) | 1.5 | - | 5 | 200 | 70-75 |
| | | Lamb on the spit | - | 2 | 5 | 200 | 70-75 |
| | | | 1.5 | - | 5 | 200 | 70-80 |
| 5 Fast cooking  | Frozen food | | | | | | |
| | | Pizza | 0.3 | 2 | - | 250 | 12 |
| | | Courgette and prawn pie | 0.4 | 2 | - | 200 | 20 |
| | | Country style spinach pie | 0.5 | 2 | - | 220 | 30-35 |
| | | Turnovers | 0.3 | 2 | - | 200 | 25 |
| | | Lasagne | 0.5 | 2 | - | 200 | 35 |
| | | Golden Rolls | 0.4 | 2 | - | 180 | 25-30 |
| | | Chicken morseis | 0.4 | 2 | - | 220 | 15-20 |
| | Pre-cooked food | | | | | | |
| | | Golden chicken wings | 0.4 | 2 | - | 200 | 20-25 |
| | Fresh Food | | | | | | |
| | | Biscuits(short pastry) | 0.3 | 2 | - | 200 | 15-18 |
| | | Fruitcake | 0.6 | 2 | - | 180 | 45 |
| | Cheese puffs | 0.2 | 2 | - | 210 | 10-12 | |

NB:cooking times are approximate and may vary according to personal taste .When cooking using the grill or fan assisted grill ,the dripping pan must always be placed on the 1st oven rack from the bottom .

Safety Is A Good Habit To Get Into

To maintain the efficiency and safety of this appliance, we recommend that you do the following:

- **only call the Service Centers authorized by the manufacturer**
- **always use original spare parts**
- **in case of damage to the power cord, a special purpose cord or component bought from the manufacturer or maintenance department shall be used for replacement**

When handling the appliance, we recommend you always use the purpose provided handles recessed into the sides of the oven to prevent harming people or damaging the appliance itself.

- This appliance is designed for non-professional ,house-hold use and its functions must not be changed .
- The electrical system of this appliance can only be used safely when it is correctly connected to an efficient earthing system in compliance with current safety standards .

• **When the appliance is in use ,the heating elements and some parts of the oven door become extremely hot .Make sure you don't touch them and keep children well away.**

- **Heat will be generated during its working. Caution must be observed to avoid touch of the heating element.**

The following items are potentially dangerous, and therefore appropriate measures must be taken to prevent children and the disabled from coming into contact with them:

- Controls and the appliance in general;
- Packaging (bags, polystyrene, nails, etc.);
- The appliance itself, immediately after use of the oven or grill due to the heat generated;
- The appliance itself, when no longer in use (potentially dangerous parts must be made safe).

Avoid the following:

- Touching the appliance with wet parts of the body;
- Using the appliance when barefoot;
- Pulling on the or the supply cable to unplug it from the electrical outlet;
- Improper or dangerous operations;
- Obstructing the ventilation or heat dissipation slots;
- Allowing power supply cables of small appliances to come into contact with the hot parts of the appliance;
- Exposing the appliance to atmospheric agents such as rain, or sunlight;
- Using the oven for storage purposes;
- Using flammable liquids near the appliance;
- Using adapters, multiple sockets and /or extension leads;
- Attempting to install or repair the appliance without the assistance of qualified personnel.

Qualified personnel must be contacted in the following cases:

- Installation (following the manufacturer's instructions);
- When in doubt about operating the appliance;
- Replacing the electrical socket when it is not compatible with the appliance plug.
- The temperature probe is a part of thermostat, if damaged; they shall be replaced overall by authorized service person.

Service Centers authorized by the manufacturer must be contacted in the following cases:

- If in doubt about the soundness of the appliance after removing it from its packaging;
- If the power supply cable has been damaged or needs to be replaced;
- If the appliance breaks down or functions poorly; ask for original spare parts.

It is a good idea to do the following:

- Steam cleaner cannot be used to clean the oven;
- Only use the appliance to cook food and nothing else;
- Check the soundness of the appliance after it has been unpacked;
- Disconnect the appliance from the electrical mains if it is not functioning properly and before cleaning or performing maintenance;
- When left unused, unplug the appliance form the electricity mains;
- Use oven gloves to place cookware in the oven or when removing it;
- Always grip the oven door handle in the center as the extremities of the same may be hot due to any hot air leaks;
- Make sure the knobs are in the “○” / “● ” position when the appliance is not in use ;
- Cut the power supply cable after disconnecting it from the mains when you decide not to use the appliance

any longer.

- The manufacturer may not be held responsible for any damage due to :Incorrect installation, improper, incorrect and irrational use.

Installation

Only a qualified person in compliance with the instructions provided must install the appliance. The manufacturer declines all responsibility for improper installation, which may harm persons and animals and damage property.

Important: - The power supply to the appliance must be cut off before any adjustments or maintenance work is done on it;

- Air duct is supposed to use in Ventilation.

Installation of Built-in Ovens

In order to ensure that the built-in appliance functions properly, the cabinet containing it must be appropriate .The figure below gives the dimensions of the cut-out for installation under the counter or in a wall cabinet unit.

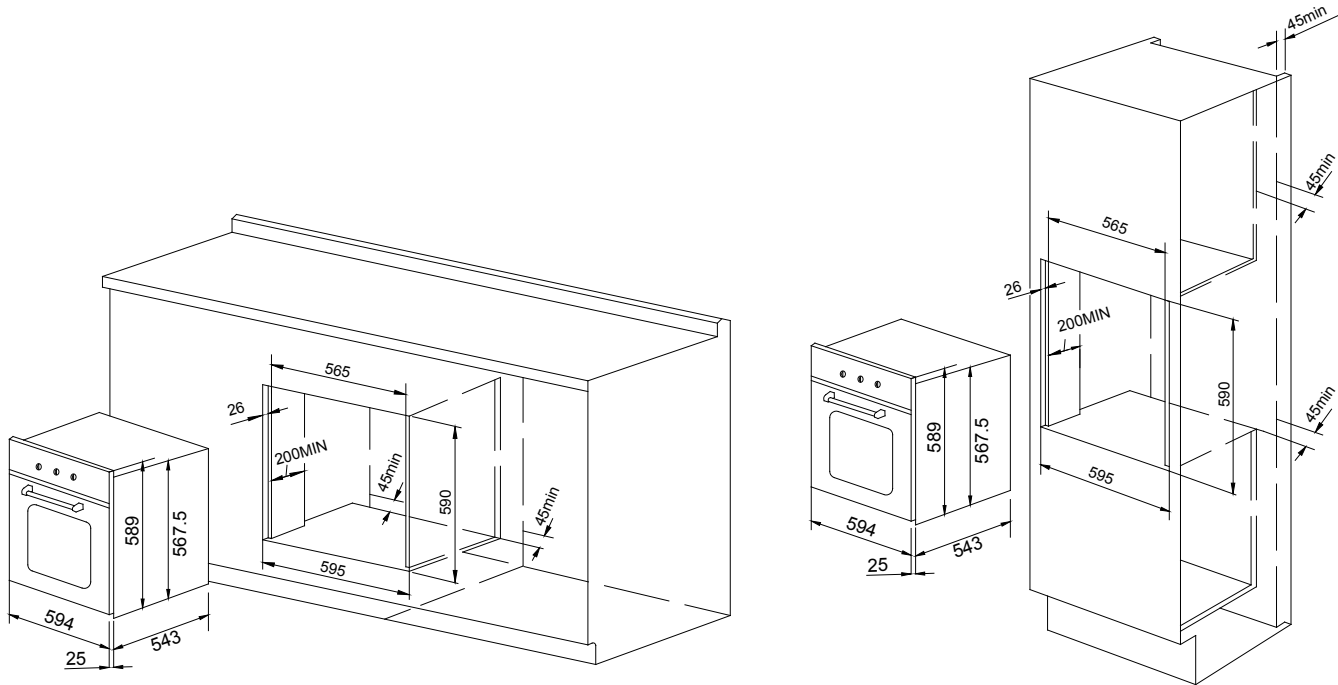

N. B :Installation in compliance with the consumption declaration

In order to ensure adequate ventilation ,the back panel of the cabinet unit must be removed .Installing the oven so that it rests on two strips of wood is preferable .If the oven rests on a continuous ,flat surface ,there must be an aperture of at least 45× 560mm .

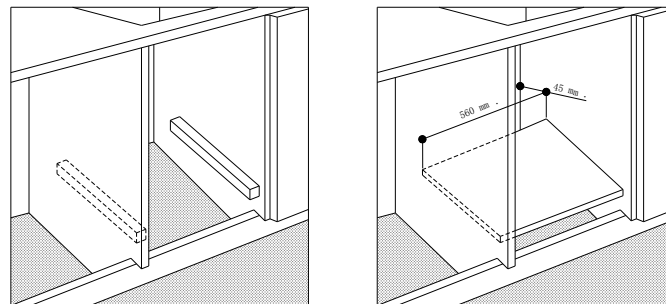

The panels of the adjacent cabinets must be made of heat-resistant material .In particular ,cabinets with a veneer exterior must be assembled with glues which can withstand temperatures of up to 100°C .

In compliance with current safety standards, contact with the electrical parts of the oven must not be possible once it has been installed.

All parts, which ensure the safe operation of the appliance, must be removable only with the aid of a tool.

To fasten the oven to the cabinet, open the door of the oven and attach it by inserting the 4 wooden screws into the 4 holes located on the perimeter of the frame.

Electrical Connection

Those ovens equipped with a three-pole power supply cable are designed to operate with an alternating

current .The wire for earthing the appliance is yellow-green in color.

Fitting on a Power Supply Cable

Opening the terminal board:

- Using a screwdriver ,prize the bolt on the side tabs of the terminal board cover ;
- Unscrew the bolt, pull open the cover of the terminal board .

To install the cable, proceed as follows:

- Remove the wire clamp screw and the three contact screws **L-N -** \perp

• Fasten the wires beneath the screw heads using the following color scheme :**Blue (N) Brown (L) Yellow-Green** \perp

- Fasten the supply cable in place with the clamp and close the cover of the terminal board .

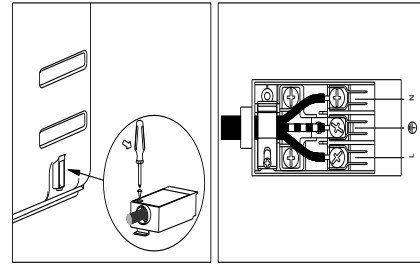

Connecting the supply cable to the mains

Install a standardized plug corresponding to the load indicated on the data plate. When connecting the cable directly to the mains, install an omni polar circuit breaker with a minimum contact opening of 3 mm between the appliance and the mains .The omni polar circuit breaker should be sized according to the load and should comply with current regulations (the earth wire should not be interrupted by the circuit breaker).

The supply cable should be positioned so that it does not reach a temperature of more than 50°C with respect to the room temperature ,anywhere along its length , or protected by insulation sleeping having an appropriate rating.

Before making the connection, check that:

- The electrical safety of this appliance can only be guaranteed if the cooker is correctly and efficiently earthed ,in compliance with regulations on electrical safety. Always ensure that the earthing is efficient; if you have any doubts call in a qualified technician to check the system .The manufacturer declines all responsibility for damage resulting from a system which has not been earthed.
- Before plugging the appliance into the mains ,check that the specifications indicated on the date plate (on the appliance and /or packaging)correspond to those of the electrical mains system of your home .
- Check that the electrical capacity of the system and sockets will support the maximum power of the appliance ,as indicated on the data plate .If you have any doubts, call in a qualified technician.
- If the socket and appliance plug are not compatible ,have the socket replaced with a suitable model by a qualified technician . The latter, in particular, will also have to ensure that the cross section of the socket cables are suitable for the power absorbed by the appliance. The use of adapters, multiple sockets and /or extensions, is not recommended. If their use cannot be avoided, remember to use only single or multiple adapters and extensions which comply with current safety regulations .In these cases, never exceed the maximum current capacity indicated on the single adapter or extension and the maximum power indicated on the multiple adapter .**The plug and socket must be easily accessible.**

Technical Specifications

Inner dimensions of the oven:

Width 43.5cm
Depth 40cm
Height 32cm

Inner Volume of the oven 56 liters

Voltage and Frequency of Power Supply:

220-240V ~50/60Hz or 50Hz



2100–2520W 2125–2560W 940–1110W 2090–2520W 2100–2550W

Meaning of crossed –out wheeled dustbin:

Do not dispose of electrical appliances as unsorted municipal waste, use separate collection facilities.

Contact you local government for information regarding the collection systems available.

If electrical appliances are disposed of in landfills or dumps,hazardous substances can leak into the groundwater and get into the food chain,damaging your health and well-being.

When replacing old appliances with new ones, the retailer is legally obligated to take back your old appliance for disposals at least free of charge.



**PRODUCT WARRANTY
REGISTRATION**
(For Singapore customers only)



Thank you for choosing Whirlpool or Ariston.
Please register your warranty online within 15 days of purchase.

3 SIMPLE STEPS TO REGISTER:

1

Go to
www.whirlpool.com.sg or
www.aristonchannel.com.sg

2

Create an account with us. You
can register warranty and check
your registered products.

3

Key in your **Product model** and
Serial Number to register!

For more information, please call our Customer Service Hotline **6250 6888** or email to helpdesk.sg@whirlpool.com.

IMPORTANT NOTICE:

Warranty is only valid and applicable to Whirlpool and Ariston products purchased from authorized dealers in Singapore. Please keep your ORIGINAL PURCHASE RECEIPT and present it for verification when required. Whirlpool Southeast Asia Pte reserves the right to reject the warranty claim not registered online. © Whirlpool Southeast Asia Pte